



**MICRO COMPUTER BASED
ELECTRONIC ZONE THERMOSTATS
T-422**



- One floating output
- Supply air temperature auto changeover

APPLICATIONS

The T-422 thermostat is designed to be used with the Young Regulator 9100 series of motorized VAV diffuser or the 4075, 3085 series damper. It operates a modulating 90 second tri-state floating actuator.

This is a true multi position modulating output. Performances are equivalent to more expensive 0 to 10 Vdc type thermostat.

ADVANCED DESIGN AND P + I CONTROL

Advanced Proportional and Integral (P + I) control thermostats provide precise temperature control and eliminates wasted energy caused by the typical On / Off cycling in conventional thermostats. Thus the room occupant is able to reduce the thermostat setpoint to the lowest comfortable setting. The result is energy savings ranging from 5% to 10%.

Individual control of zones prevents over heating & over cooling of space temperature.

SPECIFICATIONS

- Operating (32 °F to 122 °F)
- Conditions: 0% to 95% R.H. non-condensing
- Sensor: Local 47 K NTC thermistor
- Resolution: (± 0.2 °F)
- Control accuracy (calibrated): (± 0.4 °F)
- Floating output: Non isolated triac: 30 Vac at ½ A max.
- Power: 24 VAC -15%, +10% 50/60 Hz; 2 VA

DIMENSIONS

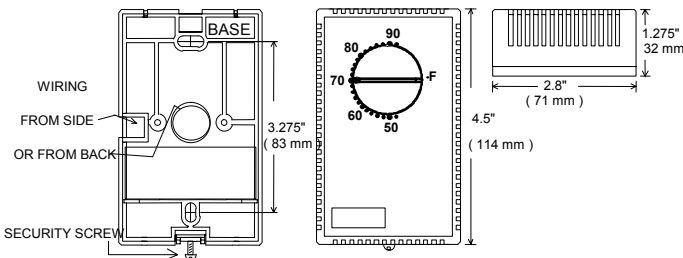

Specifications and equipment are subject to change without prior notice

MODULATING FLOATING OUTPUT

This output is designed to give true P + I modulation out of a floating actuator.

IMPORTANT - ORDER OPTIONAL SENSOR FOR AUTO CHANGEOVER

The output is normally cooling but can be reversed to heating mode with Supply Sensor model # S-422.

- **Auto changeover to heating mode with a supply sensor.**
A remote supply sensor can be used for each thermostat.
Supply temperature > 78°F (26°C) = heating mode
Supply temperature < 75°F (24°C) = cooling mode
Hysterisys is 3°F (2°C)

Characteristics of the S-422 changeover sensor 47KΩ

Temperature °F	Temperature °C	Sensor resistance
150.0 °F	65.6 °C	9.610 Kohm
140.0 °F	60.0 °C	11.700 Kohm
130.0 °F	54.4 °C	14.342 Kohm
120.0 °F	48.9 °C	17.682 Kohm
110.0 °F	43.3 °C	21.940 Kohm
100.0 °F	37.8 °C	27.412 Kohm
90.0 °F	32.2 °C	34.483 Kohm
80.0 °F	26.7 °C	43.704 Kohm
70.0 °F	21.1 °C	55.834 Kohm
60.0 °F	15.6 °C	71.866 Kohm
50.0 °F	10.0 °C	93.340 Kohm
40.0 °F	4.4 °C	122.298 Kohm

NOTE: UP TO 6 DAMPERS WITH HONEYWELL ML6161 MOTORS MAY BE WIRED OFF ONE THERMOSTAT

THERMOSTAT INSTALLATION

Important.

Electronic controllers require special care for wiring and startup. To avoid problems, carefully follow the procedures below.

Be sure to have all the literature on hand for all components installed: controller, actuators, relay, etc...

Look at the wiring diagrams, and study them carefully. Be sure that you understand how the system is supposed to work.

Make the wiring according to the wiring diagrams. Respect polarity for power terminals # 3 & # 4 between multiple controllers if the same transformer is used.

- Remove security screw on left side of thermostat cover.
- Open up by pulling on the bottom side of thermostat.

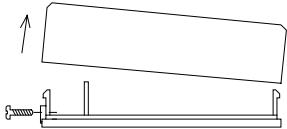

A) Location:

- 1- Shouldn't be installed on outside wall.
- 2- Must be installed away from any heat source.
- 3- Shouldn't be affected by direct sun radiation.
- 4- Nothing must restrain vertical air circulation to the thermostat.

B) Installation:

- 1- Pull out cables 6" out of the wall.
- 2- Wall surface must be flat and clean.
- 3- Separate the thermostat and the base by pulling the cover by the bottom (same as the security screw.)
- 4- Insert cable in the central hole of the base.
- 5- Align the base and mark the location of the two mounting holes on the wall. Install proper side of base up.
- 6- Install shields in the wall.
- 7- Insert screws in mounting holes on each side of the base. **DO NOT OVERTIGHTEN!**
- 8- Strip each wire 1/4 inch.
- 9- Insert each wire according to wiring diagram.
- 10- Reinstall the cover (top side first) and gently push back extra wire length in the hole in the wall.
- 11- Install security screw.

T422-1011F TYPICAL WIRING

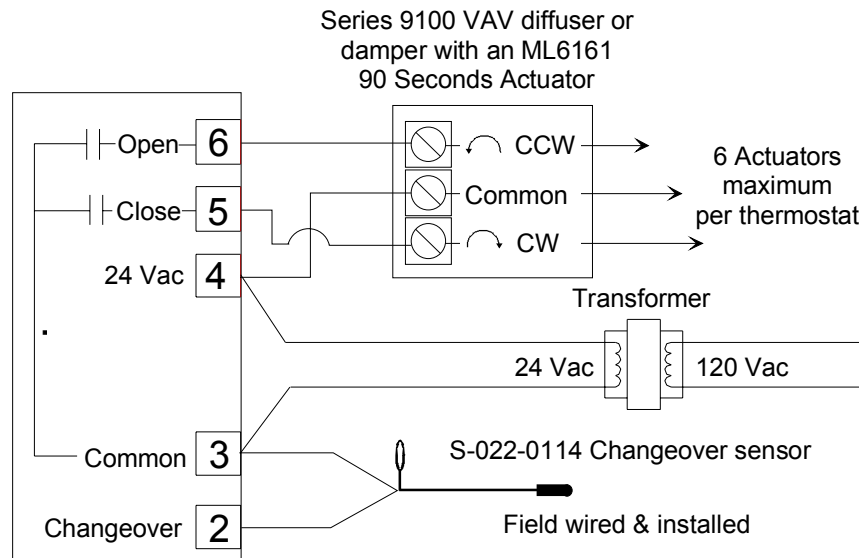

If operation of the actuator is reversed, change the open/close wires (terminals 5 & 6 on the thermostat).