

LM24-SR (-T) -2.0 US

Proportional control, non-spring return, direct coupled, 24 V, for 2 to 10 VDC and 4 to 20 mA control signal



Torque min. 35 in-lb, for control of damper surfaces up to 8 sq ft.

LM24-SR-2.0 US
LM24-SR-T-2.0 US



Application

For proportional modulation of dampers in HVAC systems. Actuator sizing should be done in accordance with the damper manufacturer's specifications. The actuator mounts directly to the damper operating shaft with a universal V-bolt clamp assembly. The actuator operates in response to a 2 to 10 VDC or, with the addition of a 500 Ω resistor, a 4 to 20 mA input signal from an electronic controller or positioner. A 2 to 10 VDC feedback signal is provided for position indication or master slave applications. (Not available on "-T" versions) The LM24-SR-2.0 US provides an electronic angle of rotation adjustment to limit the actuators rotation 20% to 100% while still using the full input signal and feedback control range. (Not available on LM24-SR-T-2.0 US)

Operation

The anti-rotation strap supplied with the actuator will prevent lateral movement of the actuator. The damper actuator is not provided with and does not require any limit switches, but is protected electronically against overload. The angle of rotation is mechanically limited to 95°. When reaching the damper or actuator end position, the actuator automatically stops. The gears can be manually disengaged by pressing a button on the actuator cover. The position of the actuator is indicated by a visual pointer.

The LM24-SR-2.0 US and LM24-SR-T-2.0 US actuators use a Brushless DC motor, which is controlled by an Application Specific Integrated Circuit (ASIC). The ASIC monitors and controls the actuator's rotation and provides a digital rotation sensing (DRS) function to prevent damage to the actuator in a stall condition.

Accessories

- 11533 T-type anti-rotation bracket
- 22065 L-type anti-rotation bracket (included)
- ZG-LMSA Shaft adaptor for short shafts
- Tool-02 8 mm wrench
- ZG-R01 500Ω resistor for 4 to 20 mA

Dimensions (All numbers in brackets are metric.)

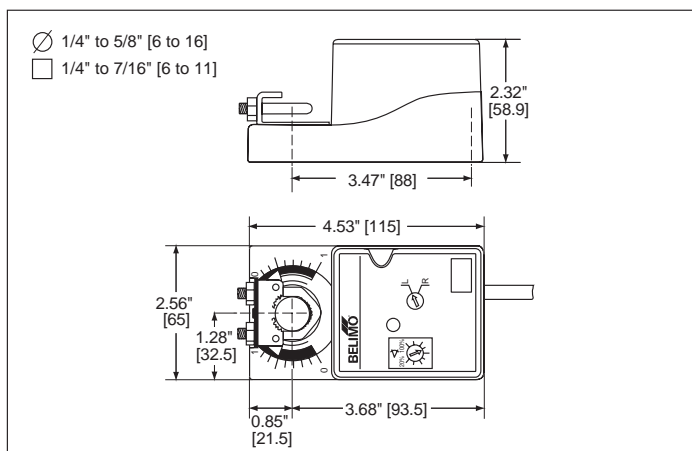

Technical Data	LM24-SR-2.0 US
Power supply	24 VAC ± 20% 50/60 Hz 24 VDC ± 10%
Power consumption	2 W
Transformer sizing	4 VA (Class 2 power source)
Electrical connection	LM24-SR-2.0 US: 3 ft, 18 GA, UL CL2P plenum cable
Overload protection	Electronic throughout 0 to 95° rotation
Operating range	2 to 10 VDC, 4 to 20 mA
Input impedance	100 kΩ (0.1 mA), 500Ω
Feedback output 'U'	2 to 10 VDC (max. 0.7 mA) (not available on LM24-SR-T-2.0 US)
Angle of rotation	max 95°, electronically adjustable 20 to 100% on LM24-SR-2.0 US
Torque	min 35 in-lb, Independent of load
Direction of rotation	reversible with switch CW/CCW CW = with an increase in voltage CCW = with a decrease in voltage
Position indication	clip-on indicator (not on "-T" models)
Running time	95 seconds
Manual override	external push button
Humidity	5 to 95% RH, non-condensing
Ambient temperature	-22°F to +122°F [-30°C to +50°C]
Storage temperature	-40°F to +176°F [-40°C to +80°C]
Housing type	NEMA type 2 (-T models Nema type1)
Housing material rating	UL 94-5V
Noise level	less than 35 dB (A)
Servicing	maintenance free
Agency listings	UL 873 listed, CSA 22.2 No. 24 certified, CE
Quality standard	ISO 9001
Weight	1.2 lbs [0.55 kg]

LM24-SR-T-2.0.1 US

Electrical connection	Screw terminals (for 26 to 14 GA wire)
Angle of rotation	max 95°, adjust. with mechanical stops
Housing	NEMA type 1
Feedback	No feedback with the LM24-SR-T-2.0 US

Proportional control, non-spring return, direct coupled, 24 V, for 2 to 10 VDC and 4 to 20 mA control signal

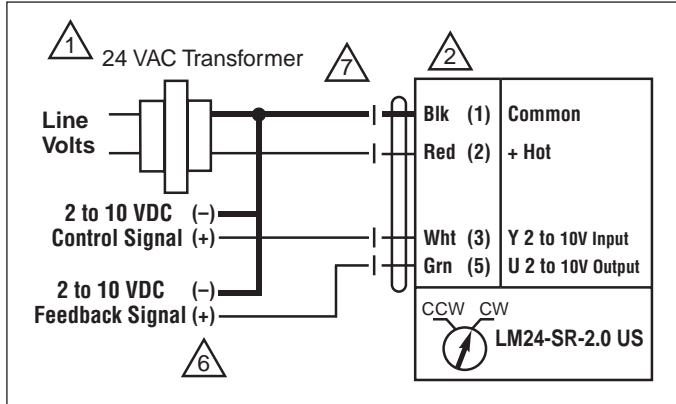

2 to 10 VDC control of LM24-SR-2.0 US

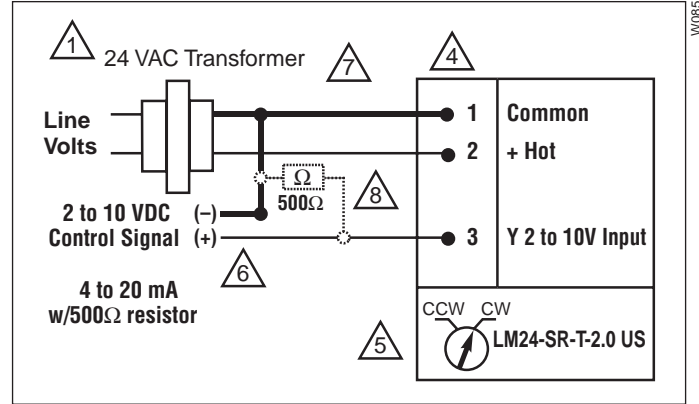

2 to 10 VDC and 4 to 20 mA control of LM24-SR-T-2.0 US

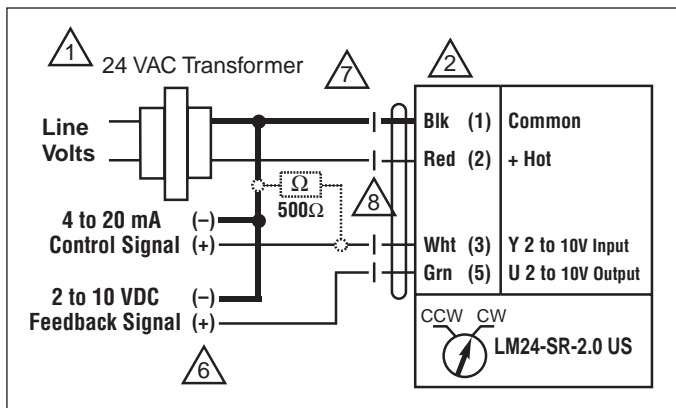

4 to 20 mA control of LM24-SR-2.0 US with 2 to 10 VDC feedback output

Notes

- 1 Provide overload protection and disconnect as required.
- 2 Actuators are provided with color coded wires. Wire numbers are provided for reference.
- 4 The LM24-SR-T-2.0 US is provided a screw terminal instead of cable.
- 5 The LM24-SR-T-2.0 US does not have feedback.
- 6 Connect actuator common (Wire 1) to Negative (-) leg of control circuits only.
- 7 Actuators may also be powered by 24 VDC.
- 8 A 500Ω resistor (ZG-R01) must be added for 4 to 20 mA control.

T-Type bracket

These are included in the single-actuator packages and are available at no extra cost in the bulk packages upon request.

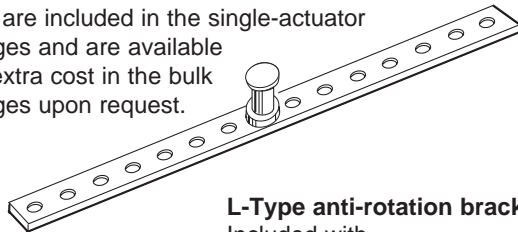

L-Type anti-rotation bracket.

Included with each bulk packaged actuator. Part number: 22065

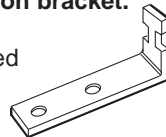

Bulk packaging LM24SR-2.0 US and LM24SR-T-2.0 US

Bulk Pack No.	Actuator Type	Quantity/Pack
LM24-SR-2.0.1 US	LM24-SR-2.0 US	32
LM24-SR-T-2.0.1 US	LM24-SR-T-2.0 US	48

To have better control of job site inventory and reduce the environmental impact of unnecessary packing material.

LM24-SR (-T) 2.0 US - Typical Specification:

Control damper actuators shall be electronic direct coupled type which require no crank arm and linkage. Actuators shall be UL and CSA listed, have a 5 year warranty, and be manufactured under ISO 9001 International Quality Control Standards. Actuators shall have Brushless DC motor. Actuators shall have reversing switch and gear disengagement button on the cover, and be electronically protected from overload at all angles of rotation. Actuators shall respond to 2 to 10VDC output relative to position regardless of the amount of damper rotation. A 2 to 10 VDC feedback signal shall be provided for position indication or master-slave applications. Actuators shall be as manufactured by Belimo.

An electronic angle of rotation adjustment shall be provided to reduce the actuators rotation from 100 to 20% while still using the full input signal and feedback control range. (LM24-SR US) If required, actuator will be provided with screw terminal strip for electrical connections (LM24-SR-T US).