

## 4041 Pressure Independent Variable Air Volume Damper

The Young 4041 Round Pressure Independent Variable Air Volume Damper is ideal for automation control companies that require flexibility to mount various manufacturers' controls and actuators. Order shell and plate only or with one of several different manufacturers' flow sensors that are available. Factory mounting of controls by others available.

### FEATURES

- Heavy duty galvanized 20ga. steel shell. Stiffening beads for superior rigidity, no crimps.
- 20 ga. galvanized steel "V" blade secured with 1/2" steel shafts. Oil impregnated bearings require no lubrication.
- 11" x 11" plate of 18ga. galvanized steel for controls and actuators.
- EPDM seals for less than 2% leakage at 3" w.c.

### OPTIONS

- A number of different actuators including pneumatic, 24V and 110V electric.
- 4 point cross flow sensor (shown)
- Probe style flow sensor.

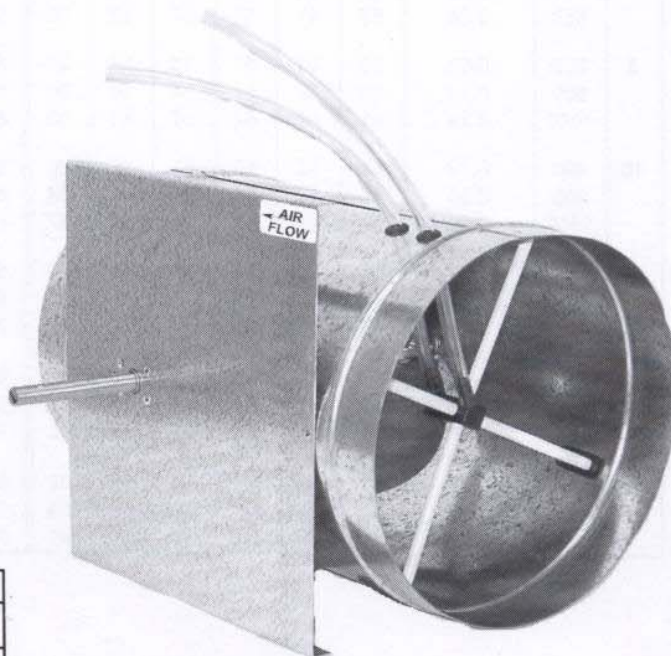

SIZE	DIAMETER	LENGTH	CFM
6"	5 7/8"	12"	0-400
8"	7 7/8"	12"	0-800
10"	9 7/8"	12"	0-1350
12"	11 7/8"	12"	0-2100
14"	13 7/8"	14"	0-2500
16"	15 7/8"	16"	0-3500

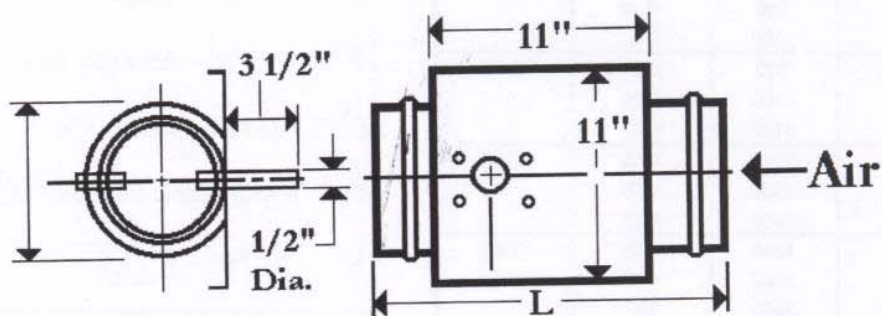

**YOUNG REGULATOR COMPANY**  
20910 Miles Parkway • Cleveland, Ohio 44128  
(216) 663-5646 • Fax (216) 663-1830

### DISCHARGE SOUND DATA

SIZE	AIR FLOW CFM	MINIMUM SUPPLY PRESSURE	1.0" PRESSURE DROP LW-CENTER FREQ.					NC.	2.0" PRESSURE DROP LW-CENTER FREQ.					NC.	3.0" PRESSURE DROP LW-CENTER FREQ.					NC.
			125	250	500	1000	2000		125	250	500	1000	2000		125	250	500	1000	2000	
6	150	0.03	49	50	47	43	48	18	50	52	50	50	52	22	53	53	52	54	54	23
	350	0.13	55	57	54	52	55	28	59	59	61	59	62	32	61	61	66	62	66	35
	550	0.28	57	61	57	57	59	36	60	64	64	62	64	38	62	66	68	68	67	41
8	250	0.02	53	51	51	48	57	27	55	54	55	56	62	32	56	56	57	61	66	34
	600	0.11	58	57	57	54	59	31	62	63	65	61	65	38	64	65	69	65	68	42
	1000	0.29	61	61	62	57	61	33	65	67	68	65	68	42	68	70	72	69	71	46
10	400	0.02	52	55	55	52	55	30	57	60	61	57	62	38	59	63	65	60	66	40
	900	0.08	60	57	58	56	58	34	65	64	65	63	64	42	69	68	69	67	68	46
	1500	0.31	54	59	61	58	59	37	71	69	68	66	66	44	75	70	70	70	69	49
12	550	0.02	53	52	55	50	52	33	57	58	60	61	61	34	60	62	63	65	64	35
	1400	0.11	62	58	62	57	57	40	68	65	65	64	63	43	71	68	67	67	67	46
	2200	0.29	66	62	66	61	59	43	72	69	70	68	66	48	75	73	72	72	70	51
14	700	0.02	57	55	51	55	57	33	61	58	55	59	60	38	63	60	57	62	62	43
	1800	0.08	63	61	59	57	61	39	68	66	65	64	67	45	71	69	68	68	72	50
	2900	0.27	67	65	64	59	63	42	73	71	69	67	69	48	76	74	72	72	74	53
16	850	0.03	56	55	52	54	59	33	62	59	56	60	61	39	66	62	59	63	63	49
	2300	0.09	64	61	60	58	61	39	71	67	66	65	68	46	74	69	68	69	70	53
	3800	0.29	68	65	64	62	63	41	73	72	70	68	73	49	79	75	74	74	75	57

Part No.	Diameter in Inches	CFM	Minimum Static Pressure	K Factor
4041-06	5 7/8"	200	0.04	2.79
		300	0.09	
		400	0.16	
4041-08	7 7/8"	400	0.05	2.91
		600	0.11	
		800	0.20	
4041-10	9 7/8"	750	0.07	2.62
		950	0.12	
		1350	0.23	
4041-12	11 7/8"	900	0.05	3.00
		1300	0.10	
		2100	0.27	
4041-14	13 7/8"	1000	0.05	2.94
		1600	0.10	
		2500	0.27	
4041-16	15 7/8"	1500	0.05	2.87
		2300	0.10	
		3500	0.27	

#### USEFUL FORMULAS ON AIR FLOW RELATIONSHIPS

FPM = Feet Per Minute Air Velocity

CFM = Cubic Feet Per Minute

$\Delta P$  = Differential Pressure (Inches W.G.)

Pt = Total Pressure

FPM =  $CFM \div \text{Area (Sq. Ft.)}$

$\Delta P = (FPM \div 4005)^2 \times K$

Pt = Min. Static Pressure +  $\Delta P$

$K = CFM \div \sqrt{\Delta P}$